

BCP - HYDRAULIC SUPPLY BLOCKS

IFISME s.r.o.

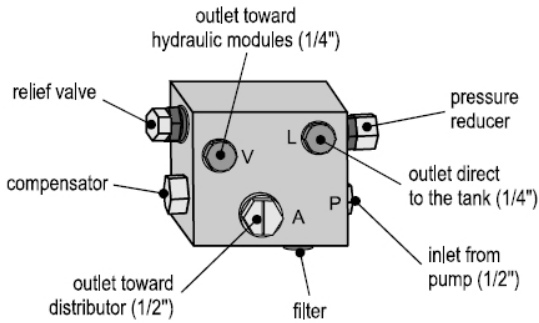

BCP01 - Max oil flow 70 lt/min

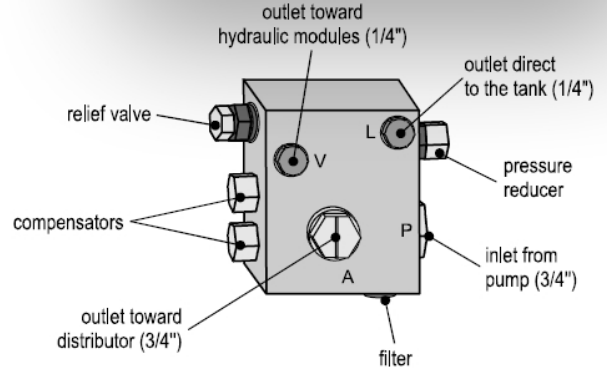

BCP02 - Max oil flow 140 lt/min

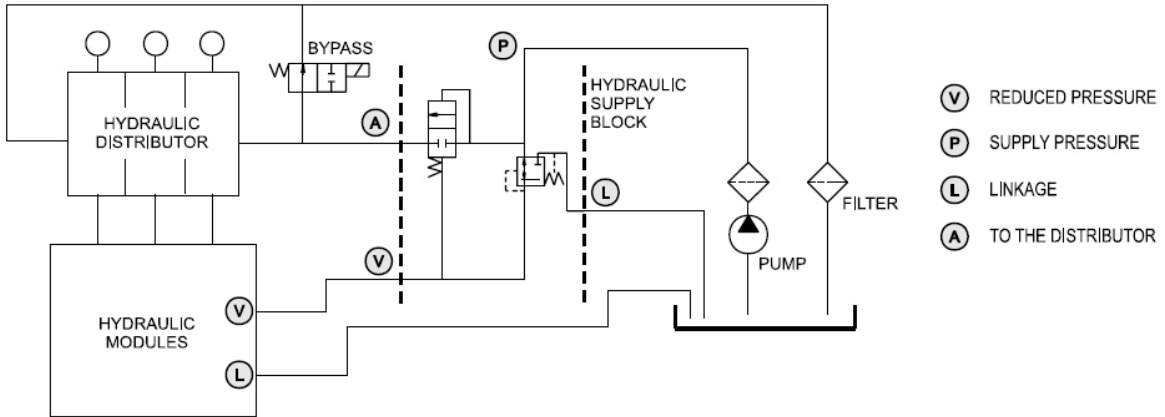

TYPICAL APPLICATION: HYDRAULIC CIRCUIT

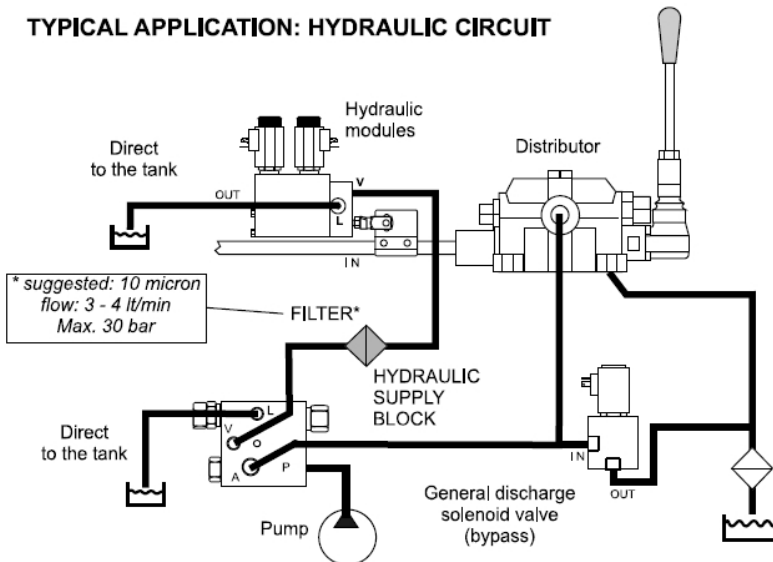

TECHNICAL DATA SHEET

Max flow	70 l/min 140 l/min
Pressure working	210 bar in P 18 ÷ 25 bar in V 1 bar in L
Maximum pressure	350 bar
Default filtering	ISO4406 18/14
Fluid	20-150 cSt
Body material	Aluminium
Weight	70 l/min : 1,2 Kg 140 l/min : 2,3 Kg
Dimensions (mm)	70 l/min: 133x83x50 140 l/min: 148x115x50